



Cambridge International Examinations
Cambridge International General Certificate of Secondary Education

CANDIDATE
NAME

CENTRE
NUMBER

--	--	--	--	--

CANDIDATE
NUMBER

--	--	--	--

* 1 9 6 5 5 1 4 7 8 1 *



COMBINED SCIENCE

0653/22

Paper 2 (Core)

May/June 2014

1 hour 15 minutes

Candidates answer on the Question Paper.

No Additional Materials are required.

READ THESE INSTRUCTIONS FIRST

Write your Centre number, candidate number and name on all the work you hand in.

Write in dark blue or black pen.

You may use an HB pencil for any diagrams or graphs.

Do not use staples, paper clips, glue or correction fluid.

DO NOT WRITE IN ANY BARCODES.

Answer **all** questions.

Electronic calculators may be used.

You may lose marks if you do not show your working or if you do not use appropriate units.

A copy of the Periodic Table is printed on page 28.

At the end of the examination, fasten all your work securely together.

The number of marks is given in brackets [] at the end of each question or part question.

This document consists of **26** printed pages and **2** blank pages.

- 1 (a) In many countries, vehicle speeds are measured by speed cameras to see if they are exceeding the speed limit. The camera takes two photographs of a vehicle after it passes the camera.

Fig. 1.1 shows a moving van about to pass a speed camera.

The van drives over lines painted on the road at 1 metre intervals.

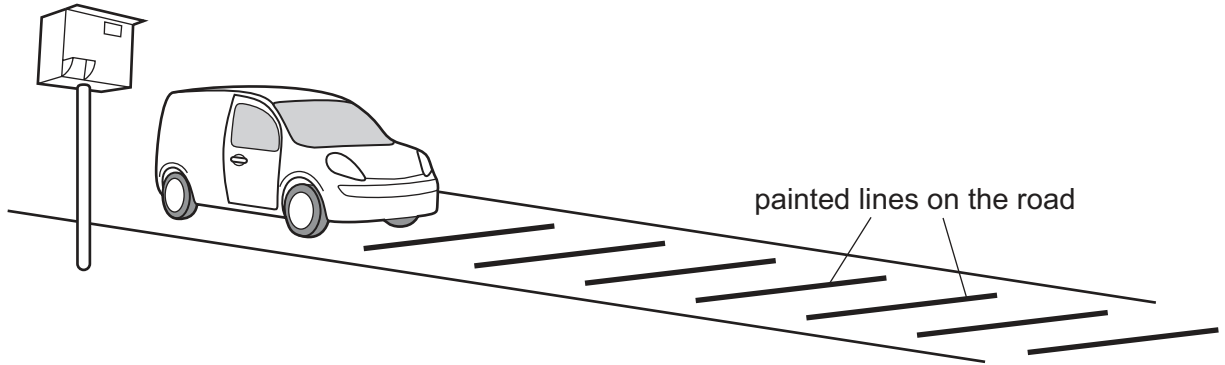

Fig. 1.1

Fig. 1.2 shows the position of the van as the camera takes the first photograph. Fig. 1.3 shows the position of the van 0.2 seconds later, as the camera takes the second photograph.

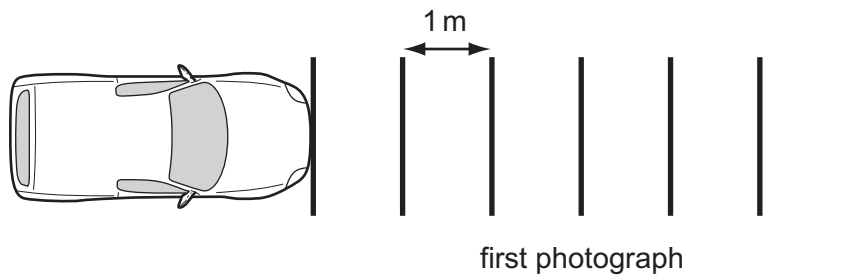

Fig. 1.2

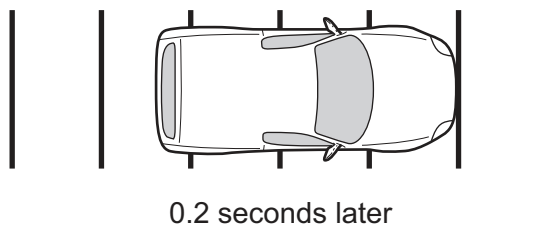

Fig. 1.3

- (i) State the distance travelled by the van between the first and second photograph.

..... m [1]

- (ii) Show, by calculation, that the speed of the van is 25 m/s.

State the formula that you use and show your working.

formula

working

[2]

- (iii) The speed limit on this road is 80 km/h.

Show, by calculation, that the van is breaking the speed limit when its speed is 25 m/s.

There are 3600 seconds in 1 hour.

Show your working.

the speed of the van = km/h [2]

- (b) The van enters a town where the speed limit is 50 km/h. The driver applies the brakes to slow down.
 - (i) Complete Fig. 1.4 by drawing **two** arrows to show the forces acting to slow down the van. Label each arrow to show the name of the force acting.

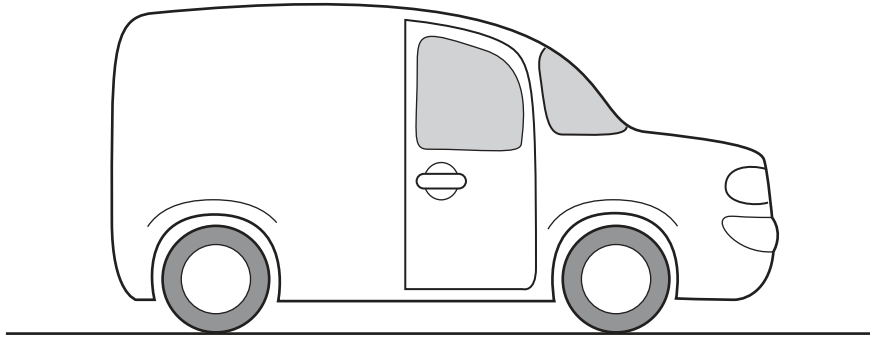

Fig. 1.4

[2]

- (ii) When the van slows down, it loses kinetic energy.

State what happens to most of the kinetic energy that is lost.

.....

..... [1]

Please turn over for Question 2.

2 Fig. 2.1 shows a water lily. The leaves of the water lily float on the surface of water.

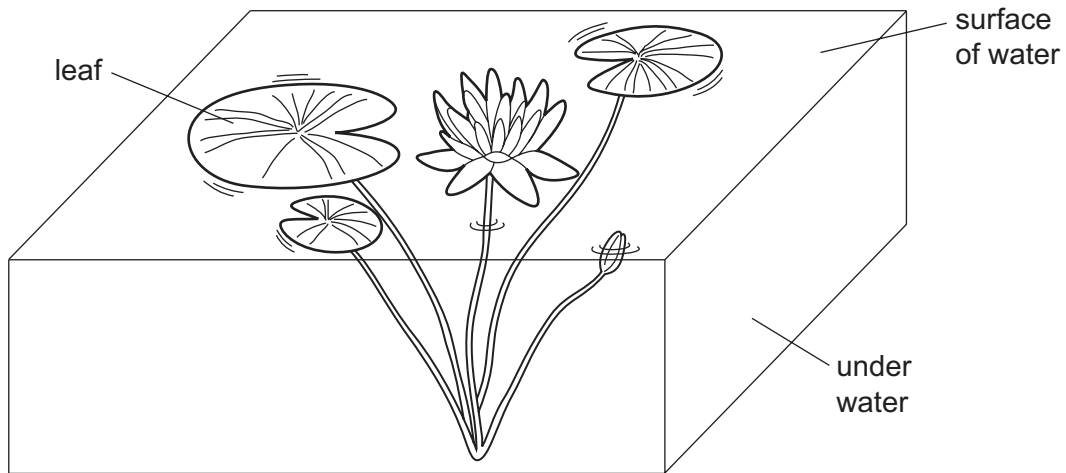

Fig. 2.1

The water lily produces carbohydrates by photosynthesis.

(a) Complete the following sentence.

In photosynthesis, plants use light energy to produce sugar and
 from carbon dioxide and

[2]

(b) Fig. 2.2 shows a cross-section of a small part of a water lily leaf as seen under the light microscope.

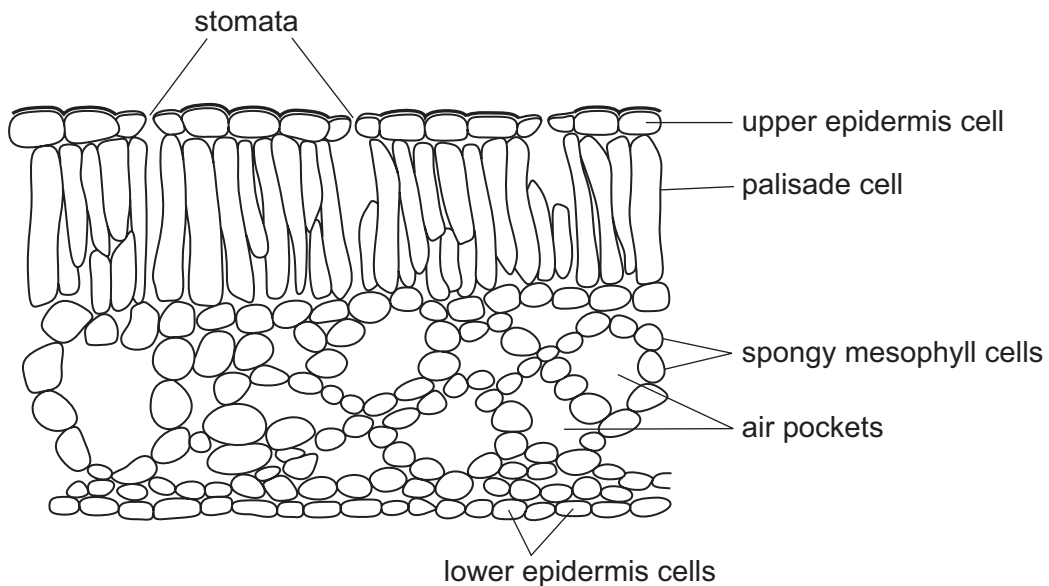

Fig. 2.2

Suggest how the large size of the air pockets in the leaf adapts the water lily to its habitat.

.....

[1]

(c) The stomata are found in the **upper** surface of the leaf of the water lily.

Suggest why this is an advantage to the plant.

.....
.....
..... [2]

(d) The roots of most plants have root hair cells but water lily roots do not.

Suggest why the roots of water lily plants do **not** need root hair cells.

.....
.....
..... [2]

(e) Some raw sewage is washed into the pond where the water lily is growing.

Explain why this causes the fish in the pond to die.

.....
.....
.....
..... [3]

3 (a) Copper slowly corrodes in air, forming a thin black coating of copper oxide. Copper oxide is an insoluble base which can be removed by reacting it with acid. The reaction forms a blue solution.

(i) State the type of compound formed when a base reacts with an acid.

..... [1]

(ii) Suggest an acid which could be used to produce copper chloride from copper oxide.

..... [1]

(b) A different compound of copper and oxygen exists. It is coloured red and contains twice as many copper atoms as oxygen atoms.

Deduce the chemical formula of red copper oxide. [1]

(c) The corrosion of iron is called *rusting*.

(i) State the **two** substances which must be present to cause the rusting of iron.

..... and [2]

(ii) Describe a method of rust prevention and explain how it works.

.....

 [2]

Please turn over for Question 4.

4 (a) When muscles contract they use energy released from respiration.

Complete the word equation for aerobic respiration.



(b) Oxygen is brought to the muscle cells by the red blood cells. Fig. 4.1 shows a cross-section diagram of a red blood cell.

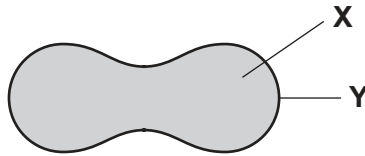

Fig. 4.1

Name the cell parts X and Y.

X

Y

[2]

(c) Starch is a good source of glucose for respiration. It must be digested by enzymes before it can be used.

Explain fully why starch must be digested.

.....
.....
.....
..... [3]

- (d) A student does some exercise to find out if there is a relationship between type of exercise and pulse rate.

She measures and records her pulse rate when resting. She performs one type of exercise then immediately measures her pulse rate again. She repeats this procedure for two more types of exercise. Each exercise is performed for the same length of time.

She allows her pulse to return to the resting measurement between each exercise.

Her results are shown in Table 4.1.

Table 4.1

type of exercise	pulse rate / beats per minute
resting	74
walking slowly	87
walking quickly	116
running	163

State which exercise produced the greatest increase in pulse rate and calculate this increase.

type of exercise

increase in pulse rate = beats/minute [2]

- (e) Describe the trend shown by the results in Table 4.1.

.....

 [2]

- 5 (a) (i) State **one** difference between the **physical** properties of metals and of non-metals.

.....
 [1]

- (ii) Table 5.1 shows the elements of the third period of the Periodic Table.

Table 5.1

Group								
I	II		III	IV	V	VI	VII	0
Na	Mg		Al	Si	P	S	Cl	Ar

Describe how the metallic character of these elements changes across the period.

..... [1]

- (b) Table 5.2 shows the properties of some elements in Group I of the Periodic Table.

Table 5.2

name of element	melting point / °C	reaction with water
lithium	181	metal remains solid and a gas is given off
sodium	98	metal melts and a gas is given off quickly
potassium	64	metal melts and the gas given off catches fire

- (i) Complete the **word** equation for the reaction between sodium and water.

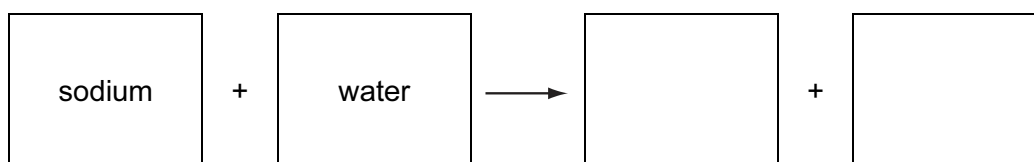

[2]

- (ii) Describe the trends in the properties of the Group 1 elements shown in Table 5.2.

.....

 [2]

- (c) When hot sodium is held in a gas jar of chlorine, it burns. Sodium chloride forms on the walls of the jar.

The apparatus used is shown in Fig. 5.1.

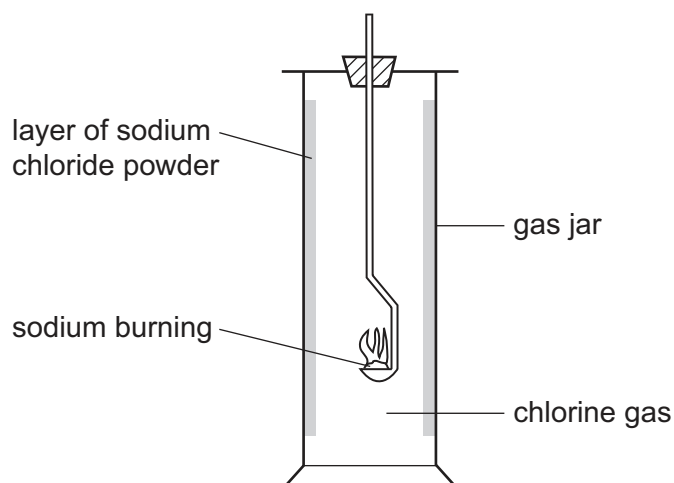

Fig. 5.1

Sodium chloride is an ionic compound made up of sodium ions, Na^+ , and chloride ions, Cl^- .

Describe how these ions are formed when sodium and chlorine atoms react.

.....

.....

..... [2]

6 Fig. 6.1 shows a flower that reproduces by insect pollination.

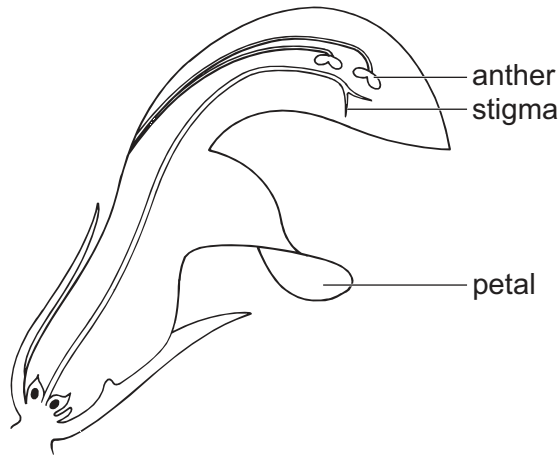

Fig. 6.1

(a) Complete the paragraph using the words in the list. You may use the words once, more than once, or not at all.

- anther colour noise platform
 pollen sepal stigma

The of the flower attracts an insect which lands on the provided by the petal. The insect enters the flower to feed from the nectar and at the same time pollen from the sticks to its body. When the insect goes to another flower the is placed on the [5]

(b) Fig. 6.2 shows a pollen grain from an insect-pollinated flower.

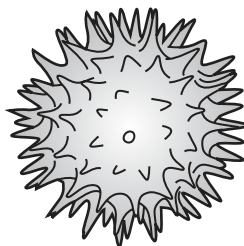

Fig. 6.2

Suggest how the structure of this pollen grain adapts it for insect pollination.

.....
 [1]

Please turn over for Question 7.

- 7 Fig. 7.1 shows a solar-powered lantern. It uses photovoltaic (solar) cells which charge a battery during the day.

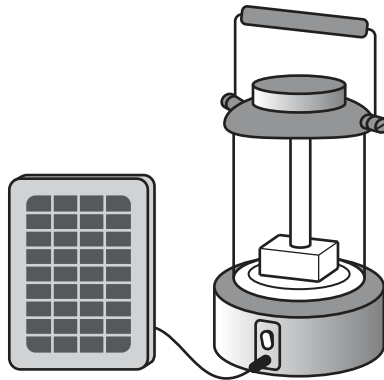
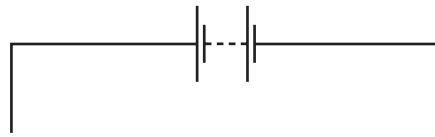

Fig. 7.1

- (a) When the lantern is switched on, the battery supplies a current to the lamp which emits light.

Complete the circuit diagram for the circuit within the lantern that connects the battery to the switch and lamp.



[1]

- (b) A larger model of the solar lantern has two lamps. A special switch enables the lamps to be connected to the battery either in series or in parallel.

- (i) The two lamps each have a resistance of 6 ohms when lit.

State the combined resistance of the two lamps when connected in series.

..... ohms [1]

- (ii) The lamps are now connected in parallel instead of in series.

Describe the effect on the current taken from the battery.

..... [1]

(iii) State **one** advantage of using the lantern with the lamps connected in parallel.

.....
..... [1]

(c) A man keeps a solar lantern ready in case his mains electricity supply fails.

One night all the lights go out in his house, and he uses the lantern to investigate what has gone wrong. Fig. 7.2 shows what he finds:

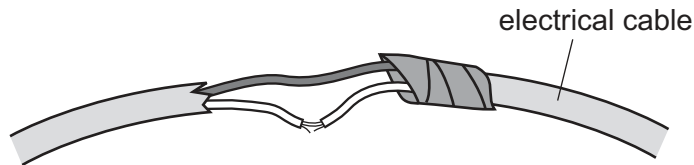

Fig. 7.2

State the hazard you can see in this picture and explain why using this cable could be dangerous.

hazard

explanation

..... [2]

(d) Fig. 7.3 shows a different electrical hazard.

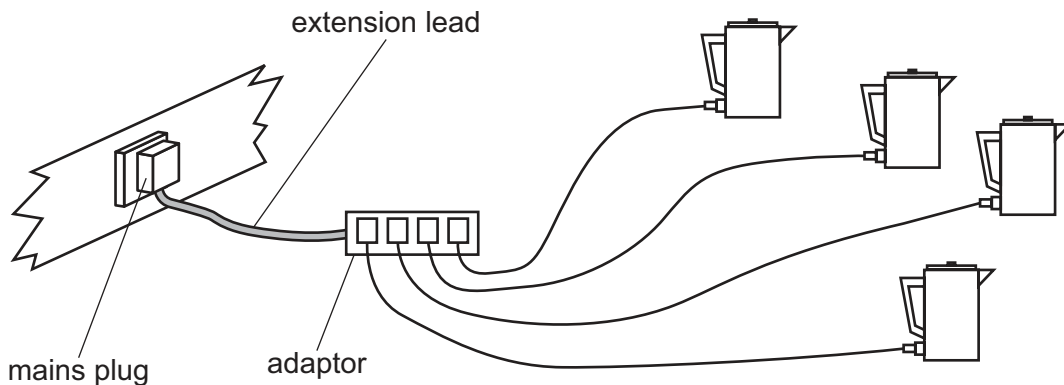

Fig. 7.3

Describe how a fuse in the mains plug can provide protection from the hazard shown.

.....
.....
..... [2]

8 Excess hydrochloric acid in the stomach can cause discomfort. Medicine containing magnesium carbonate can be used to ease this discomfort.

(a) (i) Describe and explain the effect that magnesium carbonate has on the pH of the contents of the stomach.

.....
.....
..... [2]

(ii) Magnesium carbonate produces a gas when it reacts with hydrochloric acid.

State the name of the gas and describe a test for it in the laboratory.

name

test

..... [3]

- (b) Fig. 8.1 shows that medicine containing magnesium carbonate can be supplied as a tablet in different sizes.



Fig. 8.1

Two students investigate the effect of tablet size on the rate of the chemical reaction between magnesium carbonate and dilute hydrochloric acid.

The total volume of gas produced is measured at one minute intervals from the start of the reaction. Readings are taken for a total of 10 minutes.

One student uses one 1 g tablet. The other student uses two 0.5 g tablets.

Fig. 8.2 shows some of the apparatus used.



Fig. 8.2

Fig. 8.3 shows **some** of the other apparatus that is available.

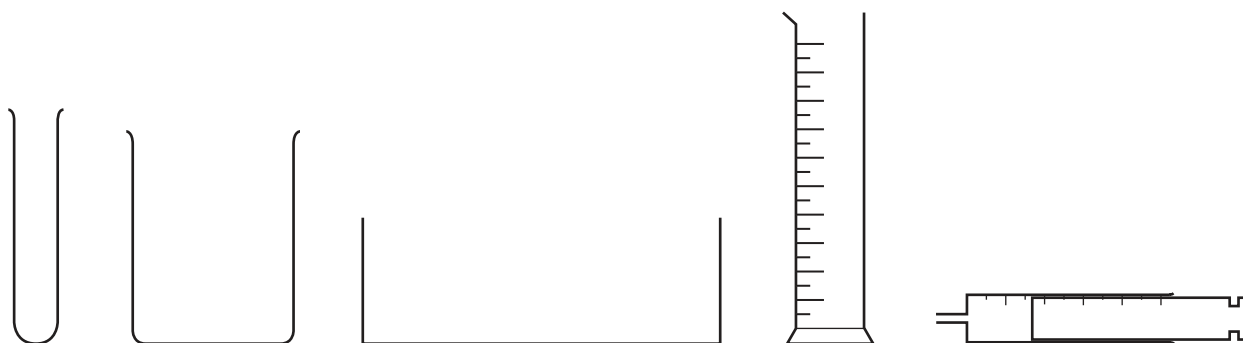

Fig. 8.3

Complete the diagram of the apparatus in Fig. 8.2 to suggest how the volume of gas produced is measured. You may wish to include some of the apparatus in Fig. 8.3.

[2]

- (c) The graph in Fig. 8.4 shows the results obtained by the student who uses one 1 g tablet of magnesium carbonate.

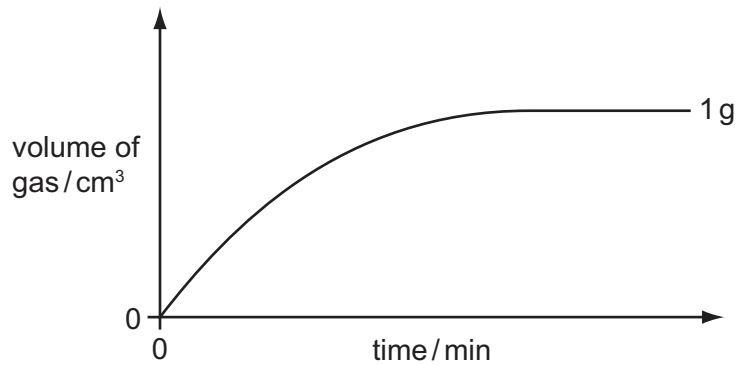

Fig. 8.4

- (i) Using the axes in Fig. 8.4, sketch a graph to predict the results obtained by the student who uses two 0.5 g tablets. [1]

Fig. 8.5 shows the label on the bottle of the medicine containing magnesium carbonate.

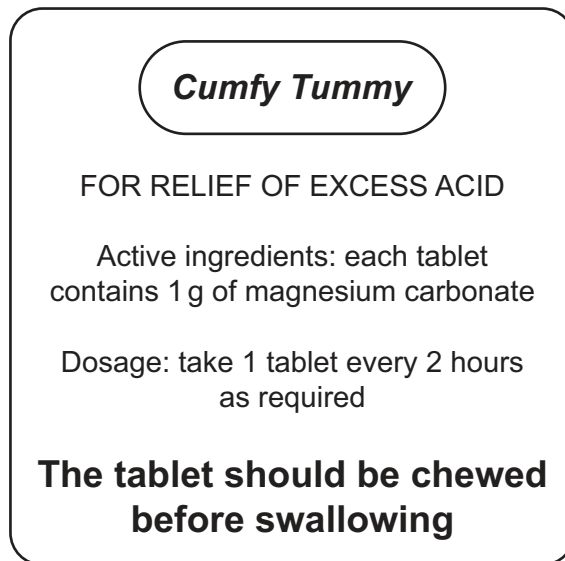

Fig. 8.5

- (ii) Explain why the tablet should be chewed before swallowing.

.....

.....

..... [2]

- (iii) Each student uses the same mass of medicine containing magnesium carbonate and the same volume of hydrochloric acid solution for his or her experiment.

The acid used in both experiments is at the same temperature before the reactants are mixed.

State what else must be kept the same in both experiments to ensure that this investigation is a fair test. Give a reason for your answer.

.....

.....

..... [2]

9 Many modern houses in colder countries are designed to conserve energy.



(a) Heat is lost from a house in many ways, through walls, doors, windows, roof and floor.

(i) State the main way by which heat is lost through solid walls.

..... [1]

(ii) Fig. 9.1 shows how the outside walls of the house are constructed. The 5 cm air gap between bricks and concrete building blocks has been filled with sheets of expanded polystyrene.

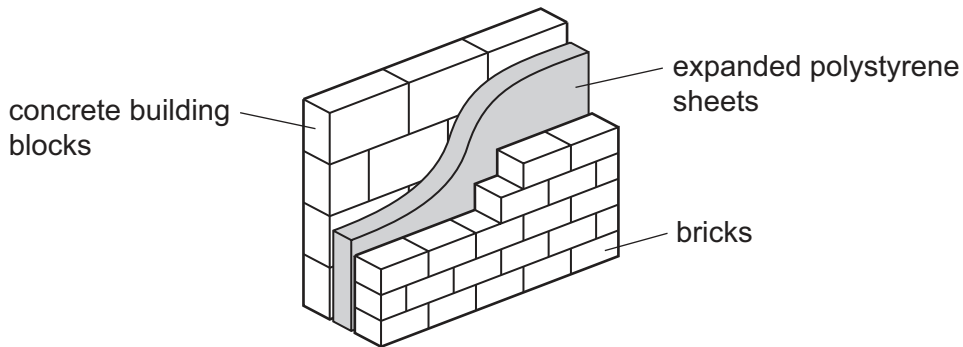

Fig. 9.1

Suggest why expanded polystyrene sheets are placed between bricks and concrete building blocks.

.....
.....
..... [2]

(b) Fig. 9.2 shows graphs of the temperatures inside and outside the house over a 24 hour period.

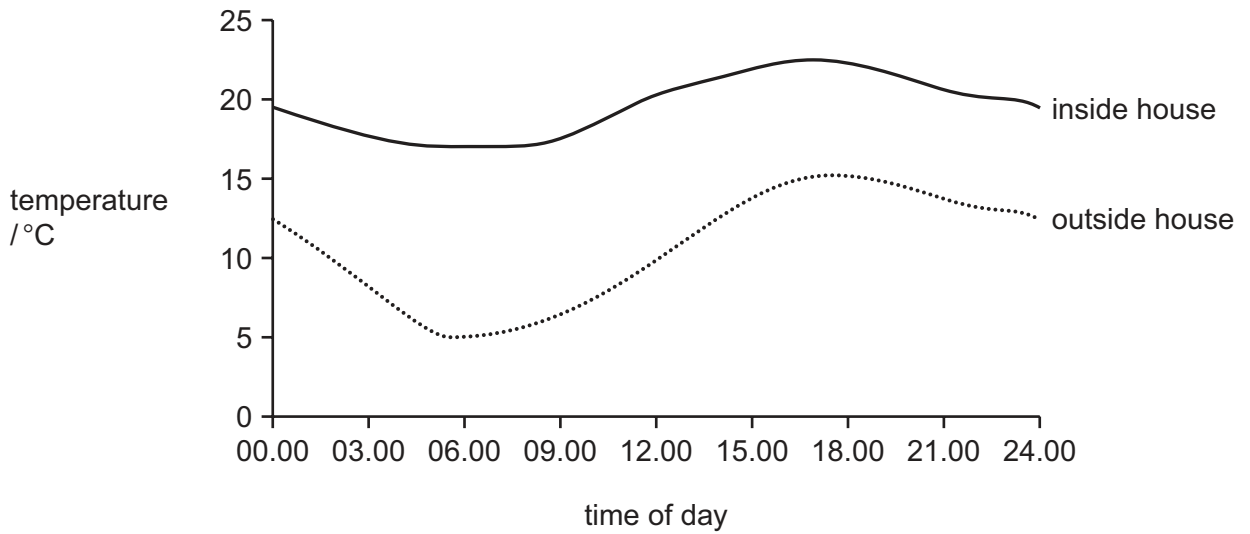

Fig. 9.2

More heat is lost when the difference in temperature between inside and outside the house is greater.

State the time of day at which heat loss from the house is greatest.

..... [1]

(c) On a hot summer day, the Sun warms the house and the temperature inside the house reaches 30°C.

(i) The people inside the house open the windows to cool the house.

State the main process by which heat is now lost from the house.

..... [1]

(ii) The Sun heats the house by electromagnetic radiation.

Fig. 9.3 shows the electromagnetic spectrum.

In the correct blank box on Fig. 9.3, write a label to name the part of the spectrum that causes the Sun to heat the house.

	X-rays		visible light		microwaves	
--	--------	--	---------------	--	------------	--

Fig. 9.3

[2]

- (d) Electricity for the house is partly supplied by a row of solar panels.

Fig. 9.4 shows the solar panels facing the Sun. In front of the solar panels is a metal mirror.

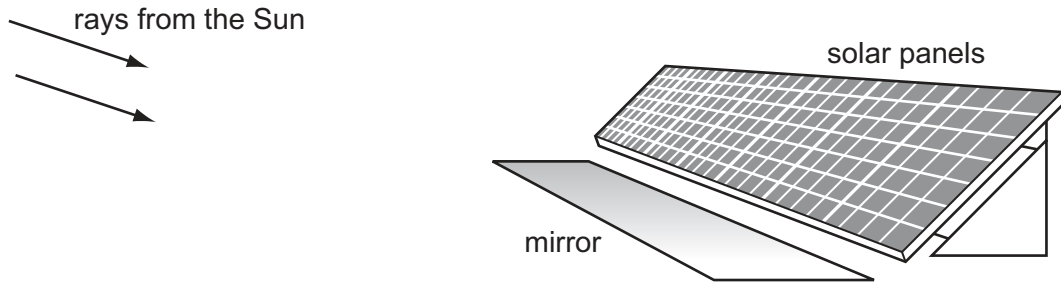

Fig. 9.4

Complete the diagram in Fig. 9.5 to show how the mirror increases the amount of the Sun's rays reaching the solar panels when the Sun is setting.

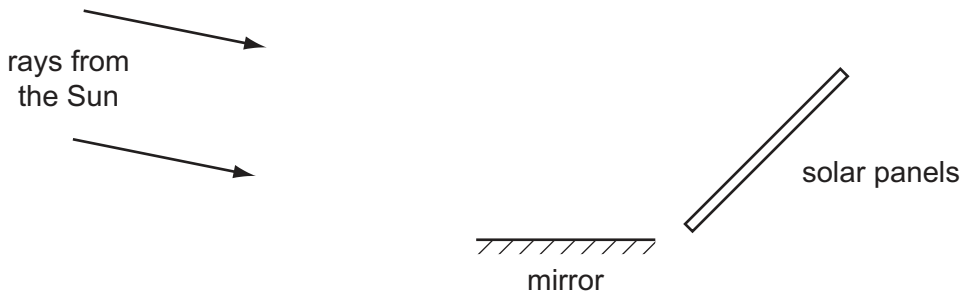

Fig. 9.5

[2]

- (e) The electrical output from the solar panels is called *direct current* and is similar to the current from a battery. For use in the house it has to be converted to a type of current called *alternating current*.

Fig. 9.6 is a graph of current against time for the alternating current supplied to the house. The graph shows a wave form.

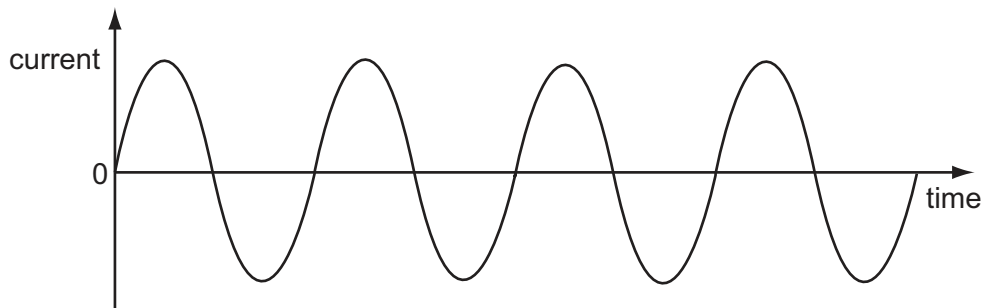

Fig. 9.6

- (i) On Fig. 9.6 mark and label one complete wave.

[1]

(ii) The wave which represents alternating current has a frequency of 50 Hz.

Explain the meaning of the term *frequency of 50 Hz*.

.....
..... [1]

DATA SHEET
The Periodic Table of the Elements

		Group													
		I	II	III	IV	V	VI	VII	VIII	IX	X	XI			
		1 H Hydrogen 1										4 He Helium 2			
7 Li Lithium 3	9 Be Beryllium 4											19 F Fluorine 9			
23 Na Sodium 11	24 Mg Magnesium 12	27 Al Aluminium 13	28 Si Silicon 14	31 P Phosphorus 15	32 S Sulfur 16	35.5 Cl Chlorine 17	40 Ar Argon 18						20 Ne Neon 10		
39 K Potassium 19	40 Ca Calcium 20	51 V Vanadium 23	52 Cr Chromium 24	55 Mn Manganese 25	56 Fe Iron 26	59 Co Cobalt 27	59 Ni Nickel 28	64 Cu Copper 29	65 Zn Zinc 30	70 Ga Gallium 31	73 Ge Germanium 32	75 As Arsenic 33	79 Se Selenium 34	84 Kr Krypton 36	
85 Rb Rubidium 37	88 Sr Strontium 38	91 Zr Zirconium 40	96 Mo Molybdenum 42	101 Ru Ruthenium 44	106 Pd Palladium 46	108 Ag Silver 47	112 Cd Cadmium 48	115 In Indium 49	119 Sn Tin 50	122 Sb Antimony 51	128 Te Tellurium 52	127 I Iodine 53	131 Xe Xenon 54		
133 Cs Caesium 55	137 Ba Barium 56	181 Ta Tantalum 73	184 W Tungsten 74	190 Os Osmium 76	195 Pt Platinum 78	197 Au Gold 79	201 Hg Mercury 80	204 Tl Thallium 81	207 Pb Lead 82	209 Bi Bismuth 83	210 Po Polonium 84	210 At Astatine 85	210 Rn Radon 86		
226 Ra Radium 88	227 Ac Actinium 89											227 Fr Francium 87			
													169 Tm Thulium 69	173 Yb Ytterbium 70	175 Lu Lutetium 71
													167 Er Erbium 68	168 Md Mendelevium 101	102 No Nobelium 102
													162 Dy Dysprosium 66	164 Fm Fermium 100	103 Lr Lawrencium 103
													159 Tb Terbium 65	159 Bk Berkelium 97	
													157 Gd Gadolinium 64	158 Cm Curium 96	
													152 Eu Europium 63	153 Am Americium 95	
													150 Sm Samarium 62	151 Pu Plutonium 94	
													144 Nd Neodymium 60	146 Np Neptunium 93	
													141 Pr Praseodymium 59	147 U Uranium 92	
													140 Ce Cerium 58	148 Pa Protactinium 91	
													232 Th Thorium 90		

*58-71 Lanthanoid series
†90-103 Actinoid series

a	X	a = relative atomic mass
b	X	X = atomic symbol
		b = proton (atomic) number

The volume of one mole of any gas is 24 dm³ at room temperature and pressure (r.t.p.).

Permission to reproduce items where third-party owned material protected by copyright is included has been sought and cleared where possible. Every reasonable effort has been made by the publisher (UCLES) to trace copyright holders, but if any items requiring clearance have unwittingly been included, the publisher will be pleased to make amends at the earliest possible opportunity.

Cambridge International Examinations is part of the Cambridge Assessment Group. Cambridge Assessment is the brand name of University of Cambridge Local Examinations Syndicate (UCLES), which is itself a department of the University of Cambridge.